

REVISIONS				
REV SYM	ECO NUMBER	DESCRIPTION	BY DATE	APP'D DATE
A		ORIGINAL RELEASE	JM 08-01-08	MK 08-01-08

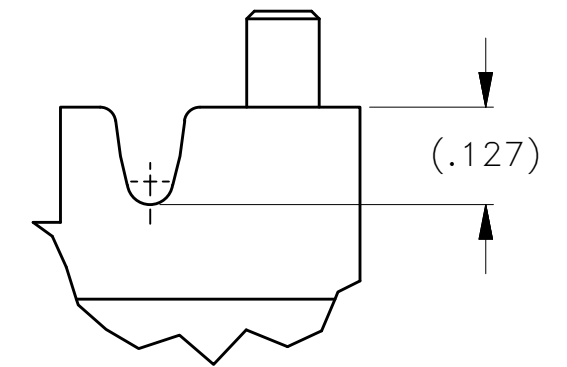
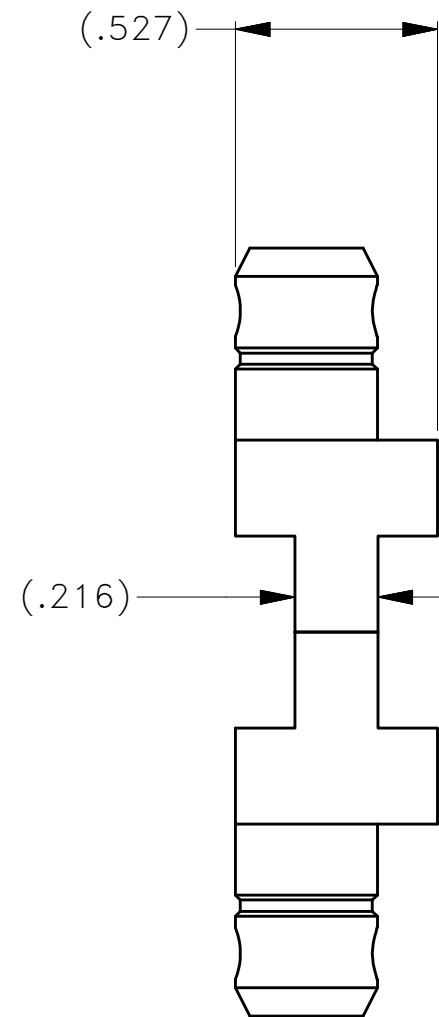
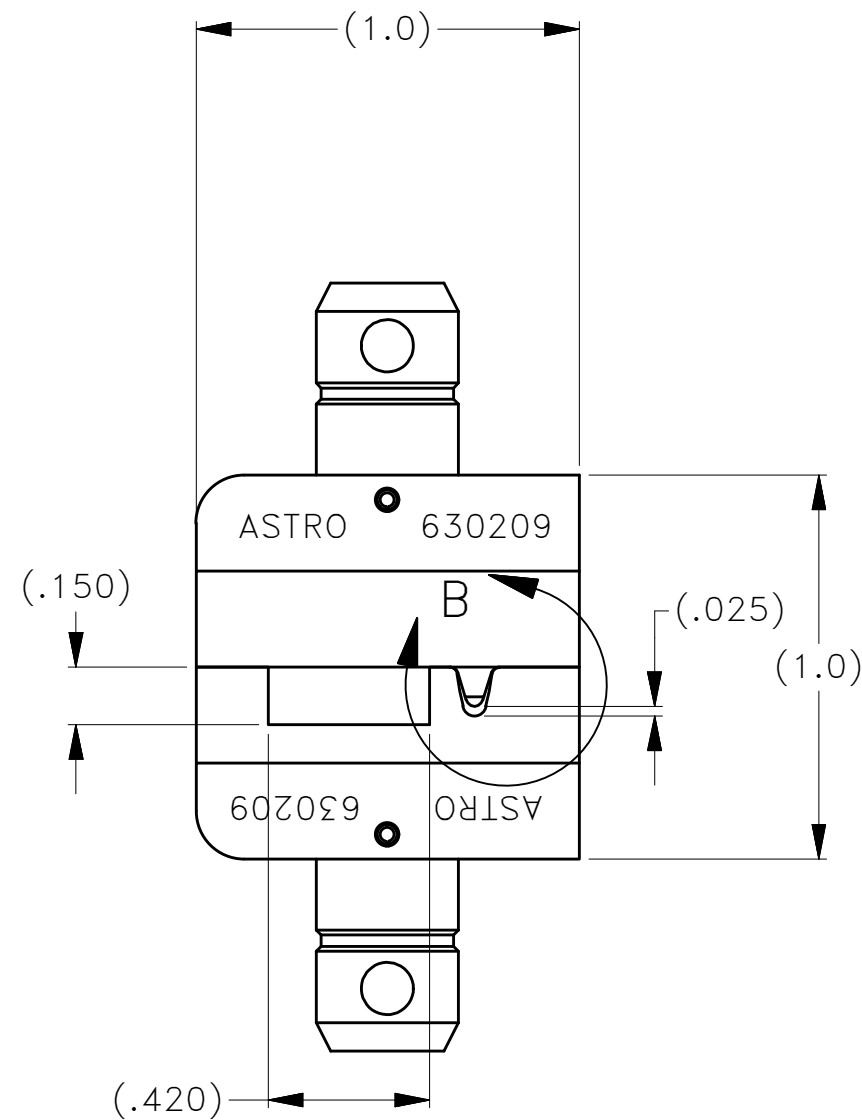

DETAIL B

**UNCONTROLLED DOCUMENT  
WILL NOT BE UPDATED**

NOTES:

1. THIS IS AN ICAD DRAWING DO NOT CHANGE MANUALLY.
2. MAT'L: REF: 0-6 TOOL STEEL

<p>THESE DRAWINGS, SPECIFICATIONS OR OTHER DATA ARE THE PROPERTY OF ASTRO TOOL CORP. AND MUST BE RETURNED UPON REQUEST. THEY CONTAIN INFORMATION OWNED AND/OR DEVELOPED BY ASTRO AT ITS OWN PRIVATE EXPENSE AND MAY NOT BE USED, DUPLICATED OR DISCLOSED TO OTHERS, IN WHOLE OR IN PART FOR DESIGN, MANUFACTURE, OR PROCUREMENT WITHOUT THE WRITTEN PERMISSION OF ASTRO TOOL CORP. EACH AND EVERY TIME.</p> <p>CREATED FROM AN INVENTOR MODEL. CHANGES MUST BE REFLECTED IN THE 3D PART</p> <p>DO NOT SCALE DRAWING</p>	MATERIAL	ITEM	PART NO.	QTY.	DESCRIPTION/REMARKS
	--	DRN.	J.MATTHEWS	DATE	08-01-08
	--	CHK'D.	MK	DATE	08-01-08
	HEAT TREAT	APP'D.	DATE	 <p>21615 S.W. TUALATIN VALLEY HWY., BEAVERTON OR 97006</p>	
--	APP'D.	DATE	TITLE		
FINISH	--	TOLERANCE:		WHERE USED:	
--	--	UNLESS OTHERWISE SPECIFIED FRACTIONS ± 1/32 ANGLES ± 1° DECIMAL INCHES:		SIZE	SCALE
		.X ± .030 .XX ± .010 .XXX ± .005 .XXXX ± .0005 REMOVE BURRS AND BREAK SHARP EDGES .005-.015		B	N.T.S.
				CAD P/N	SHEET OF
				630209_ENV	10F1
				POSTING	REV.
				P/N	A
				630209	